

A Key Player

Profile grinding machines

RAPID 650 – 800

RAPID 1000 – 1250

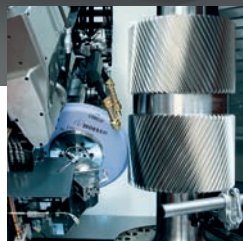

 **HÖFLER**

Maximum precision – very fast: The *RAPID* compact profile grinding machines

Today's global economy is presenting the gear industry with many new challenges, and innovative answers are coming from southwest Germany, the heartland of German engineering know-how. This is where HÖFLER is based, one of oldest and best-known suppliers of gear grinding machines. The company has been developing advanced gear grinding machines for the world market since it was founded in 1959. Today HÖFLER is regarded as the leading producer of high-precision gear profile grinding machines, a position it defends vigorously through significant investments in research and development.

The most recent example of this is the ongoing improvements to the compact *RAPID* series, known to gear manufacturers around the world for robust construction and maximum precision. With its modular design and interchangeable components, the new *RAPID* series is one of the most powerful and economical production lines for workpieces of up to 1250 mm diameter. A brand-new, ultra-flexible grinding head allows genuine 5-axes machining and opens the way to processing and product options that would have been unimaginable just a few years ago. What was once just a specialized tool has become a high-speed precision instrument for the fine machining of hard materials.



RAPID 650 – 800
RAPID 1000 – 1250

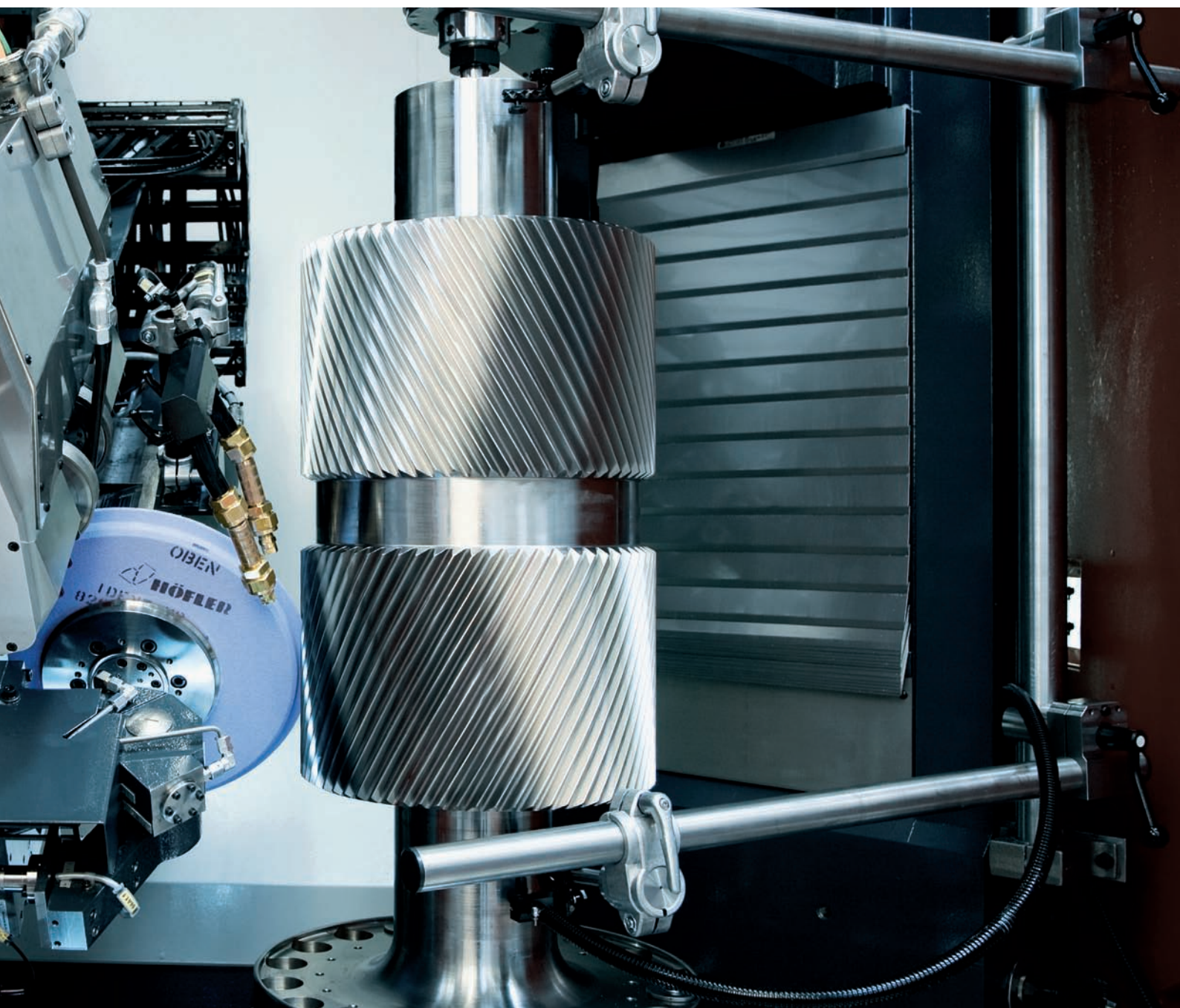

HÖFLER *RAPID* 650 – 800 and HÖFLER *RAPID* 1000 – 1250

More advanced: mineral casts for machine bases

Progress at HÖFLER starts with the materials: high-quality mineral casts are superior to the otherwise standard cast iron. Advantages: same stability but 10 times better damping properties and 25 times better thermal behavior for machine base and mechanical components. Processing heat and ambient heat in the shop floor have a significantly lower effect on the machine geometry. Result: a measurable increase in process security in profile grinding.

More stable: single bed design

Grinding accuracy is also influenced by the workholding and drive. The new series offers a stable, distortion-free machine bed in one casting, into which the machine table is directly integrated. The grinding slide executes all linear movements – the same principle for machining heavy workpieces is used in the large *RAPID* series. The table can bear more weight, and the load is transmitted to the ground through the machine bed. The table is running on hardened and ground guideways in pretensioned high-precision axial cylinder roller bearings. The bearings are constructed for a continuous load up to 3000 kg [8000 kg for the larger *RAPID* series] and offer maximum stiffness with a virtually unlimited service life.



RAPID 650 – 800

RAPID 1000 – 1250

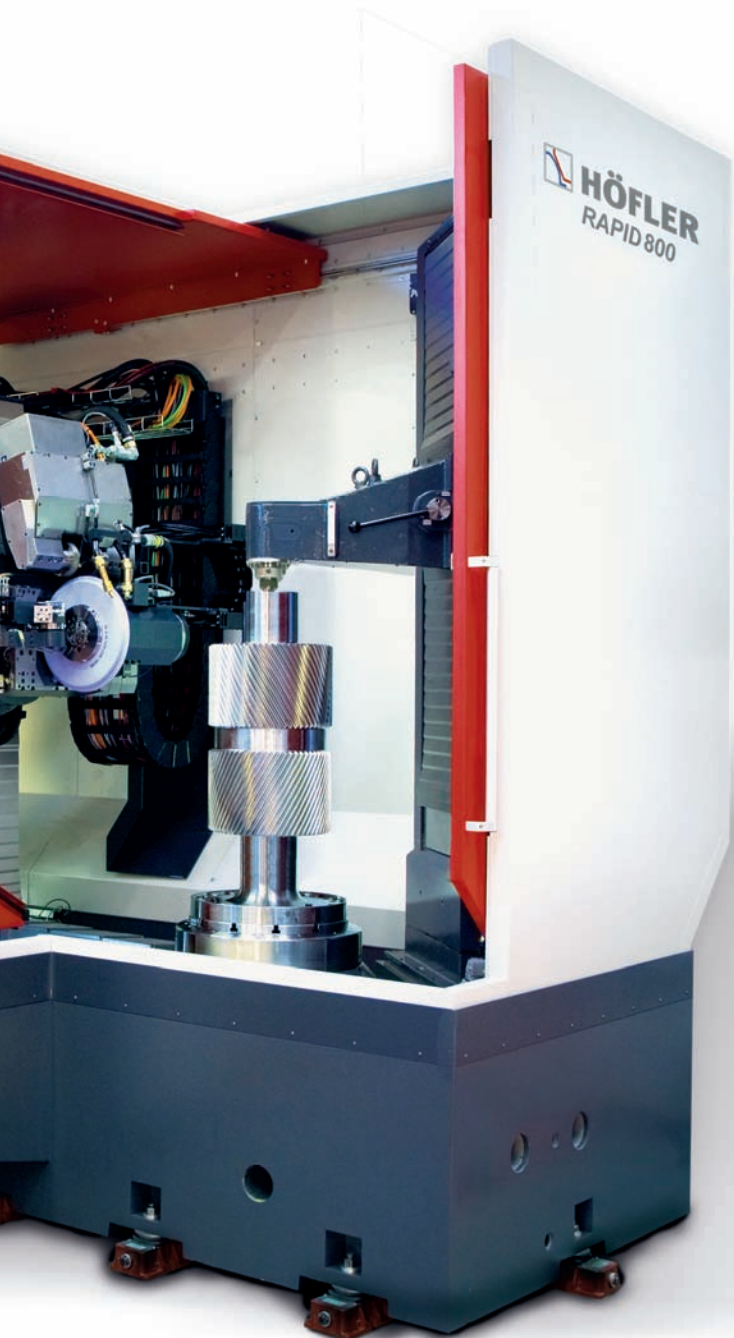

Greater accuracy: torque motor table drives

HÖFLER machine table drives with torque motors and direct measuring systems are smooth-running and backlash-free. With the high motor torque, the table can rotate at up to 45 rpm, which reduces the time needed for alignment and indexing, and even enables external cylindrical grinding of gears. Specially developed HÖFLER software allows the table drives to be adjusted quickly and automatically for the weight and inertial mass of the workpieces. The advantages: minimal configuration time, faster quality achievement. Torque motors are wear-free and never lose their accuracy – and this kind of security is an excellent argument in favor of the investment.

More flexible: grinding head with »living axes«

There are additional advantages to the new *RAPID* grinding head with torque motor swivel action. The helix angle of the head can be adjusted during grinding, while at the same time, the grinding spindle can be shifted tangentially. The result: »living axes«, or true 5-axes grinding! Advantage: The new *RAPID* allows for topological modifications to the tothing – depending on the allowable deviations in single- or double-flank grinding. A measuring device with a 3D probe integrated into the grinding head permits testing of most difficult topologies.

New advances in processing: Gear grinding with *RAPID*

The new *RAPID* series for small to medium-sized workpieces incorporates the best from more than 50 years of experience, research and development. But the goal is not simply to make a good machine even better. The HÖFLER development engineers aim to provide the many users of these machines with modular, process-specific and thus extremely economical solutions applicable to both standard and specialized tasks.

Greater productivity: operating range

The enormous axial stroke length of the *RAPID* and the extremely flexible grinding head work together to enable product options that are unique for this class of machines. Double helical gears or long pinion shafts can now be ground in one clamping operation. Worm gears, alignment journals, thrust collars and bearing shoulders can also be ground with the standard grinding head.

Superior design: torque motor grinding head rotation and double dressing system

Up to now, torque motors have been used primarily for table rotation. HÖFLER's pioneering innovation is to incorporate torque motors in the grinding head. Highest positioning accuracy, wear-free operation, rigidity and acceleration – these unique advantages of torque motors can now be applied to optimize the rotation of the *RAPID* grinding head. Monitored by a direct measuring system, the grinding head positions itself quickly and with maximum accuracy – even while grinding. A double dressing system is integrated directly into the grinding head and fitted with two dressing rolls. Result: freely dressable profile heights on the grinding wheel. The traverse paths are shorter, as are the dressing times. The dressing unit profiles the grinding wheel using various parameters – quickly, with low wear and extremely accurately.

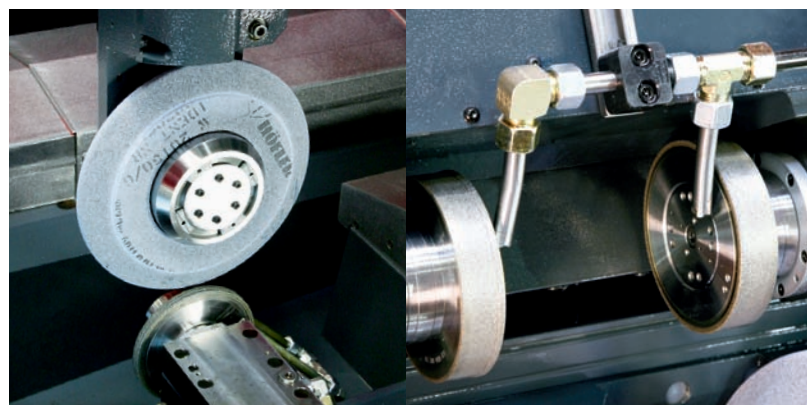
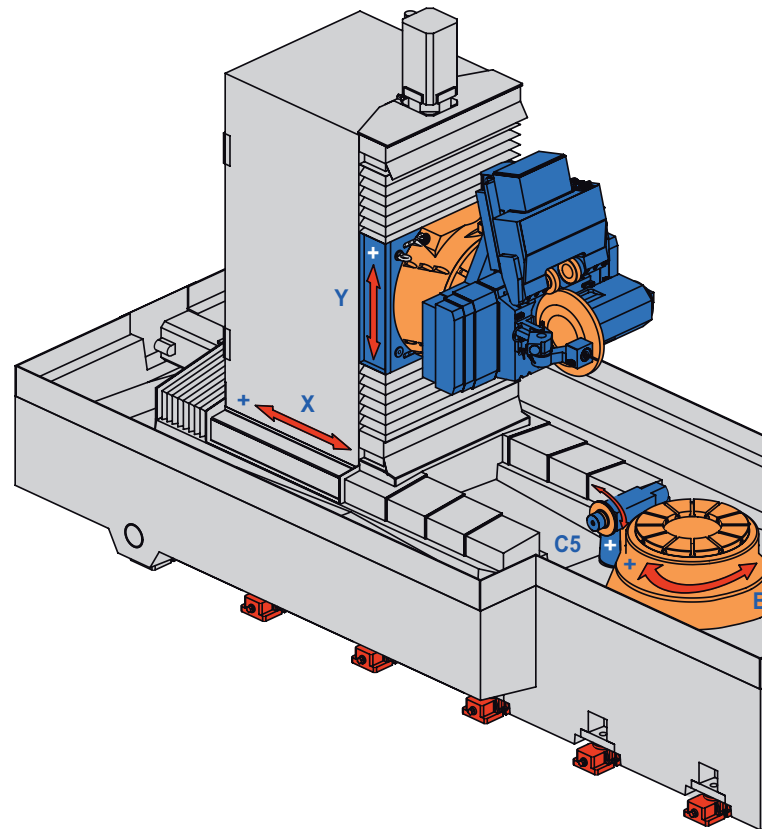
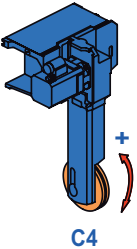

Dressing internal grinding wheel

Dressing rolls [external grinding]

FUNCTION

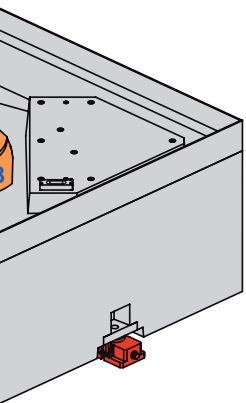
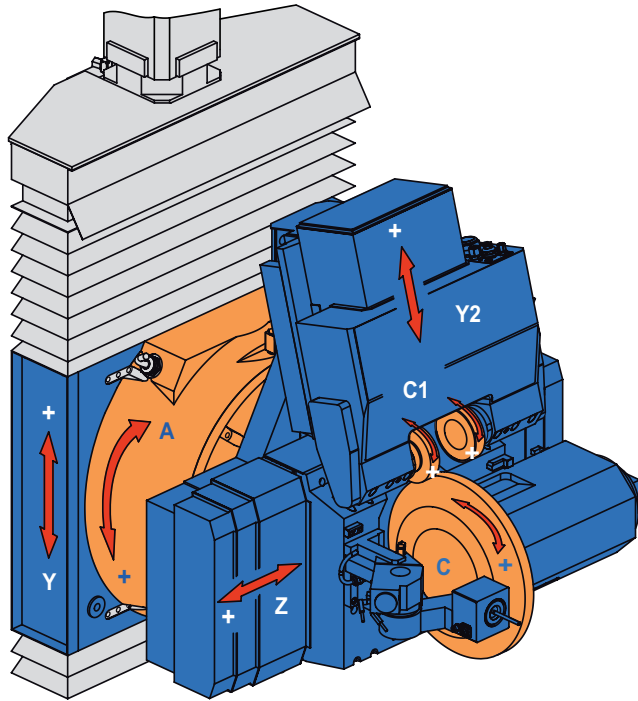

CNC Axes	
X	Tool slide
Y	Stroke slide
B	Machine table
A	Helix angle
Z	Shift axis
Y ₂	Dressing axis
C, C ₁ , C ₄ , C ₅	Controlled grinding wheel and dressing wheel drives

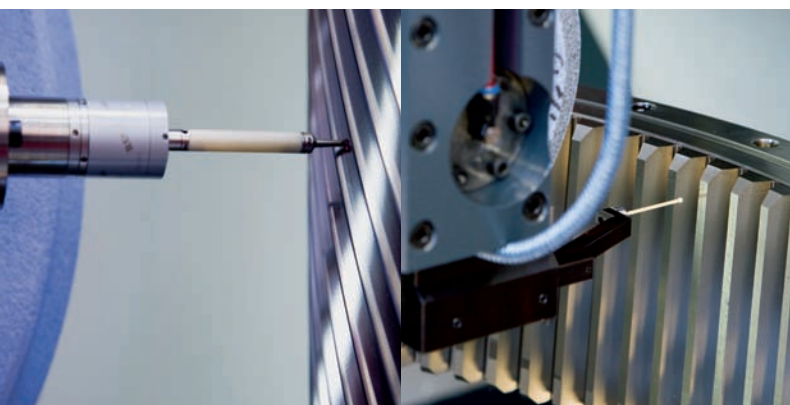

External measuring

Internal measuring

Greater functionality: internal gear grinding arm

A special, easily mounted internal grinding arm converts the *RAPID* to a powerful machine for grinding spur or helical internal gears and clutches. The internal grinding arm is dressed in the same way as for external grinding but with a separate dressing unit – including all corrections. Different internal gear grinding arms are available depending on the application or industry, e.g. aviation.

Cleaner: vacuum oil filtering system

We offer for every *RAPID* a powerful system for vacuum filtering of the grinding oil, an oil cooler, and an oil mist absorbing system for the interior.

Standard performance profiles

- Cylindrical gears and shafts
- Standard modifications in profile and lead
- Siemens electronics, Siemens 840 D control

Optional performance profiles

- Cylindrical internal gears [spur and helical]
- Gear inspection for external and internal gears
- Double helical gears [apex grinding]
- Worm grinding
- Cylindrical grinding
- Thrust collar grinding
- Alignment journal grinding
- Bearing shoulders
- Spline shaft gearing, clutch gearing
- Special profiles
- Inspection of special profiles, spline shaft, clutch and worm gearings

RAPID 650 – 800 and RAPID 1000 – 1250: Functionality and precision in numbers

The new *RAPID* series offers the legendary HÖFLER precision in a compact size with even greater operator comfort. The machine bed consists of one piece. Advantage: fast and uncomplicated assembly and disassembly.

Easy access to the large interior space means utmost operator convenience. For grinding wheel change, the operator can define the ideal change position freely.

High speed Grinding [HsG] is an attractive option for fast, high-precision production. HsG reduces grinding times by up to 40%.

Find out for yourself: come to the HÖFLER technology center for a test run.

Optional internal grinding arm

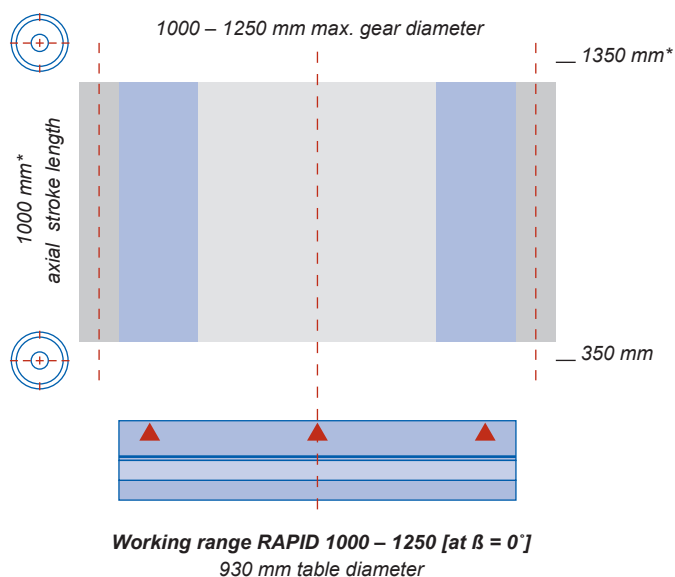
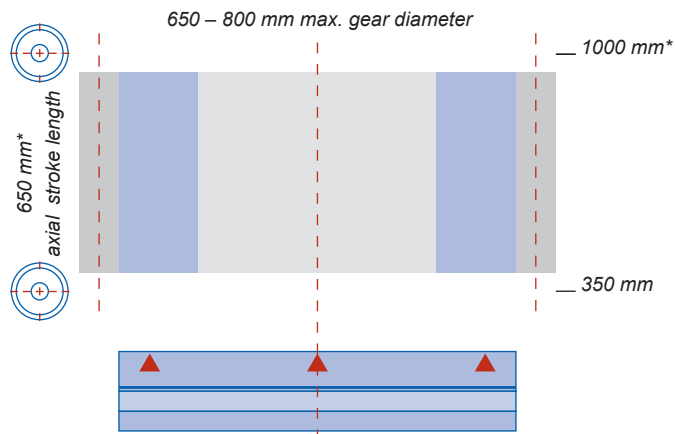
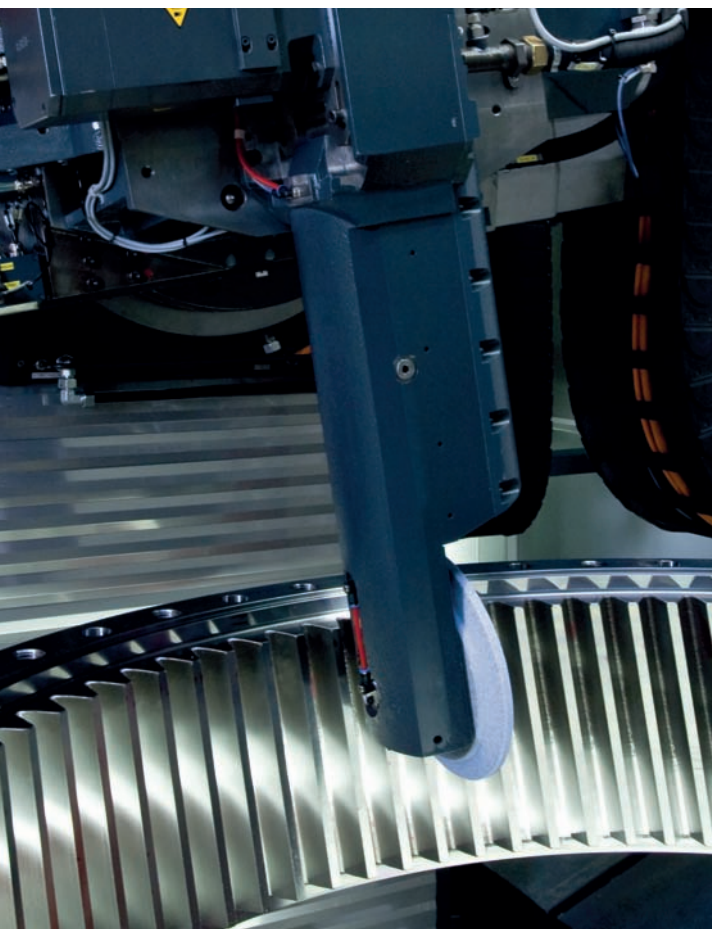

* extension available

Standard accessories

- Electrical equipment as per VDE specifications
- Multiprocessor continuous-path control with integrated PC
- Swivelling control panel with color monitor
- Manual control panel for working in the machine
- Software for job preparation at the PC
- Powerful high speed CNC grinding wheel dressing unit
- Centering and touch grinding sensor
- Wireless grinding wheel balancing unit
- Work area safety cover

TECHNOLOGY

Technical Data RAPID 650 – 1250		RAPID 650 – 800	RAPID 1000 – 1250
Gear outside diameter	max. mm	650 [800]*	1000 [1250]*
Root diameter	min. mm	0	
Axial stroke length	mm	650 [1000/1500]*	1000 [1500]*
Working range above table	mm	350 - 1000 [1350/1850]*	350 - 1350 [1850]*
Center distance above table	mm	500 - 1200 [1500/2000]*	500 - 1500 [2000]*
Profile height	max. mm	80 [60/20]**	
Module approx.	min.-approx. max.	0.5 - 35	
Pressure angle	degr.	no restriction	
Helix angle	degr.	- 45 / + 120	
Grinding wheel diameter	max. mm	400 [300/100]**	
Grinding wheel diameter [shoulder]	min. mm	206 [110/20]**	
Grinding wheel thickness	max. mm	90 [60/20]**	
Grinding spindle drive power	max. kW	24 [37]* [38.5]**	
Stroke speed of tool slide	max.	6000 [12000]*	
Table diameter	mm	500	930
Workpiece table load	kg	3000	8000
Table bore diameter x length	mm	Ø 210 x 700	Ø 370 x 400
Table rotation	min.-max. rpm	0 - 45	0 - 30
Dressing roll diameter x width	mm	Ø 120 x 26	
Machine weight	kg	23000 - 26000	28000 - 30000
Space requirement	l x w x h	5.0 x 7.1 x 3.2	5.7 x 7.1 x 3.6
Internal grinding		Various internal grinding arms available*	

* available at additional cost

Subject to change

** K-models: optional grinding spindle for small grinding wheels [available at additional cost]

- Operative-control panel cooling
- Error diagnostic system and service modem
- Operating manual, circuit diagrams, manufacturer's certificate
- Hydraulic unit with cooler

Optional accessories

- Counter support optional with center or steady rests
- Internal grinding unit for internal spur and helical gears
- Integrated gear inspection system
- Software – special profiles

- Software – grinding from solid stock
- Software – targeted preset of apex point
- Software – topological grinding
- Software – grinding reference collars and alignment journals
- Software – grinding worms and spindles
- Grinding wheels, diamond dressing rolls, filter material
- Vacuum grinding oil filtering system

Adding value with knowledge: HÖFLER *GearPro* Software

HÖFLER has been able to maintain its position as a technological leader with large investments in research and development. One of the payoffs: *GearPro*, the versatile software for HÖFLER profile grinding machines. *GearPro* gives users access to more than 50 years of experience with grinding strategies and processes.

Greater competitiveness: stock distribution

The *RAPID* competitive edge: grinding processes can be controlled directly with the power input and major machining parameters. Comparative measurements document wear in the grinding wheel and, if necessary, adjustments are made to the process. Dressing cycles can be optimized for stock removal and stroke movements depending on the stock per flank. Sensors and automatic touch grinding analyze the stock per flank before grinding – in this way stock removal can be automatically distributed over all tooth gaps. This saves unnecessary dressing cycles, prevents stroke movements, accelerates the process and improves the security of the results.

Greater versatility: profile modifications

Only the *GearPro* software »awakens« the dressing unit and the *RAPID*'s highly flexible grinding head. Multiple profiles can be dressed quickly and accurately – coarse and open for high stock removal rates, fine for superior surface quality. The standard software enables profiling of almost all involute profiles. Profile modifications are displayed graphically on the monitor. A free program enables point-by-point input of special profiles into an x/y coordinate system.

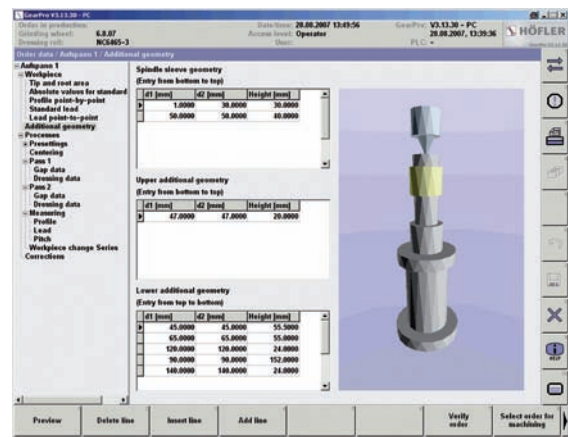

GearPro interface:
visually and clearly structured

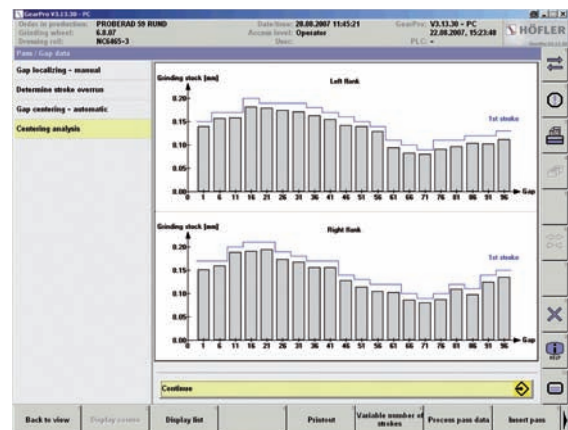

SOFTWARE

Greater reliability: lead modifications

GearPro makes it easy to program any kind of lead modification for both single- and double-flank grinding. The form and correction values are simply entered at the monitor and are displayed graphically.

Greater perfection: topological grinding

The ever-increasing pace of industrial progress is placing great demands on the machine-building industry for ever more flexible solutions. One example would be gear profile grinding machines capable of producing multiple tooth-profile topologies – with minimized deviations. HÖFLER has developed an algorithm for the *RAPID* that can calculate optimum axial paths depending on the desired topology of the tooth profile. The optimum grinding wheel profile is calculated accordingly. The *RAPID* uses this algorithm to grind topologically modified tooth profiles in single- or double-flank grinding – with deviations approaching zero.

Easier to use: operator functions

Setting up jobs, changing workpieces, configuring the machine, monitoring processes – *GearPro* can do all this in just a few steps. *GearPro* displays the machine status and processes graphically, making machine control more intuitive, easier and safer. Problems and even possible collisions during workpiece clamping are displayed before they become actual – and very expensive – problems in the machine itself. No other machine software offers so much transparency and ease of use for planning and organizing processes.



Service from HÖFLER: Experts on demand

HÖFLER employees have been with the company for 16 years on average, a level of dedication unusual even in this industry. The reason for this is HÖFLER's belief that continuous training is key to maintaining its competitive edge, and the company invests accordingly. Only those with the appropriate qualifications and experience ever come into contact with customers – whether as consultants, trainers or as assembly and commissioning engineers. On the other hand, customers will hardly ever see an emergency team from HÖFLER: Since HÖFLER machines are technically mature and exceptionally robust.

Quicker availability: remote maintenance

However, if serious problems do occur, professional help is just a mouseclick away. A powerful service team analyzes and corrects problems quickly anywhere in the world by remote diagnosis. They operate in virtually all time zones, and speak both German and English. Experience shows that the majority of cases can be analyzed and corrected this way. If this is not possible, HÖFLER technicians can generally be on site very quickly upon notification of a problem to take care of it – all over the world.

Better customer care: the technology center

Customers use the HÖFLER technology center to hob or grind special designs quickly and economically. At the same time, HÖFLER's philosophy is to train the customer for better results. By processing projects together, HÖFLER gets to know all customer requirements in detail and extends its own experience with grinding wheels, grinding lubricants, grinding strategies, clamping fixtures, etc. New conclusions are immediately applied to improve the machine technology for customer's benefit.



Process control



On-site service



On-site customer advice

SERVICE



*HÖFLER is a member of AGMA and FVA
and is DIN EN ISO 9001/2008 certified.*

Presence worldwide: HÖFLER Offices and Service-Points



HÖFLER Maschinenbau GmbH

Industriestraße 19
D-76275 Ettlingen / Germany

Phone: +49 / 7243 599 - 0
Fax: +49 / 7243 599 - 165
E-mail: info@hofler.com

www.hofler.com

HÖFLER Offices and Service-Points

HÖFLER USA

HÖFLER America Corporation

SALES

26 Sky Manor Road
Pittstown, NJ 08867 / USA
Phone: +1 / 908 442 4361
Fax: +1 / 908 996 6977
E-mail: usa.sales@hofler.com

HÖFLER America Corporation

SERVICE

26 Sky Manor Road
Pittstown, NJ 08867 / USA
Phone: +1 / 908 996 6922
Fax: +1 / 908 996 6977
E-mail: usa.service@hofler.com

HÖFLER Russia

Techproject Ltd.

Marschala Timoschenko Str. 17
Bld. 1, 167
121359 Moscow, Russia
Phone: +7 / 495 416 60 14
Fax: +7 / 495 416 60 14
E-mail: russia@hofler.com

WORDWIDE



HÖFLER China

HÖFLER Representative Office Beijing

Rm. 2412, Kuntai International Mansion
Yi No. 12 Chao Wai Street
Chao Yang District
Beijing 100020 / China
Phone: +86 / 10 5879 7866
Fax: +86 / 10 5879 7856
E-mail: china.sales@hofler.com

HÖFLER Yantai Service Co., Ltd.

Rm. 1212 HUAXIN INT'L.
No. 28 Changjiang Rd.
Yantai ETDZ.
Yantai 264006 / China
Phone: +86 / 535 6103 500
Fax: +86 / 535 6103 502
E-mail: china.service@hofler.com

HÖFLER India

Nemade Engineers Pvt. Ltd.

#7, Patel Complex
Bhusari Colony
Paud Road, Kothrud
Pune 411038, India
Phone: +91 / 20 252 854 73
Fax: +91 / 20 252 854 74
E-mail: nemade.engineers@hofler.com



HÖFLER Maschinenbau GmbH

Industriestraße 19

D-76275 Ettlingen / Germany

Phone: +49 / 7243 599 - 0

Fax: +49 / 7243 599 - 165

E-mail: info@hofler.com

www.hofler.com